

HEATED MIRROR KITS FITTING INSTRUCTIONS

Application: Land Rover 90, 110 & 130.
12volt with Land Rover Switch YUG000470LNF

Safety!

Before starting work on the vehicle ensure that you fully understand the procedure and have the necessary tools and parts to complete the job. If you are unsure phone Extreme 4x4 Ltd and ask for technical assistance or have the work carried out by a competent workshop.

Installation:

1) To remove mirror lens, gently warm the rubber seal holding the glass with warm water (NOT BOILING). Remove the seal and prise out the glass from the base of the lens where there is a small cut out in the plastic head.

2) Fit the control switch in a suitable place.

3) Drill 6.5mm hole in base of mirror head.

Drill 6.5mm hole at point A.

Drill 8mm hole at point B.

With the door open, drill 8mm hole in the top door hinge from inside.

4) Mount the relay in a suitable place - either under the bonnet or behind the dash.

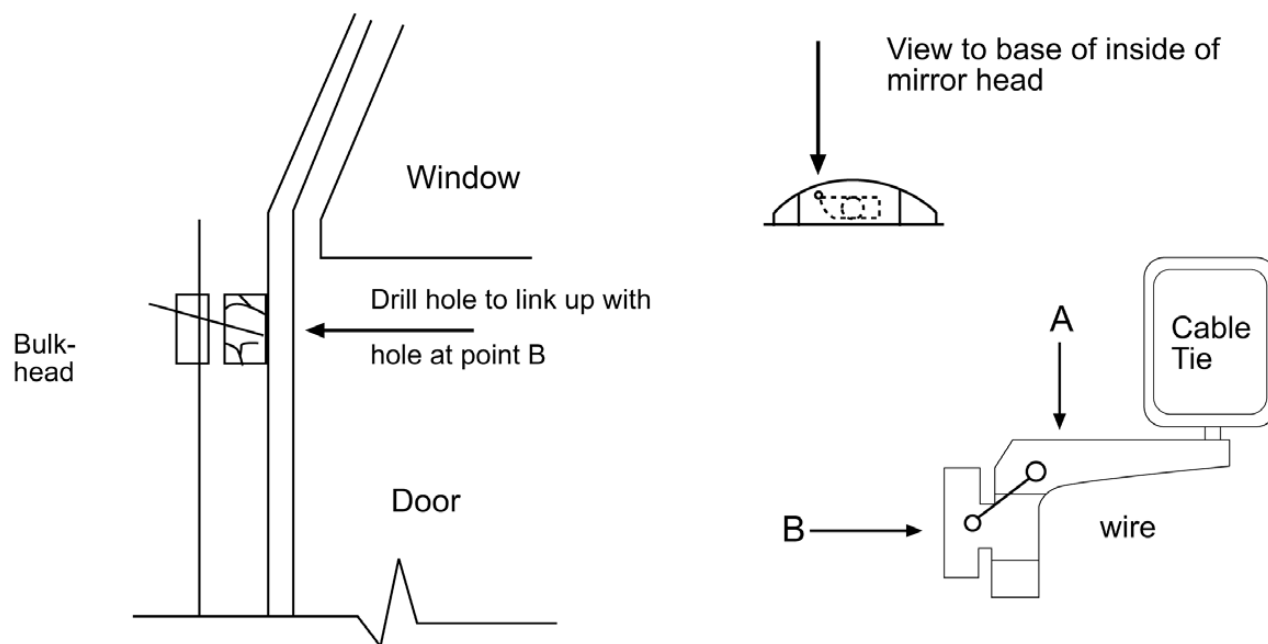

5) Thread the wires from the mirror head to the relay and a suitable earth. Some bulkhead trim may require loosening to pass wire behind them. Wire from nearside across dash to switch can run under trim in the parcel tray. Peel off backing and stick the element to the rear of the clean, dry mirror glass. Connect wires and refit glass and rubber seal. To soften seal, soak in hot water.

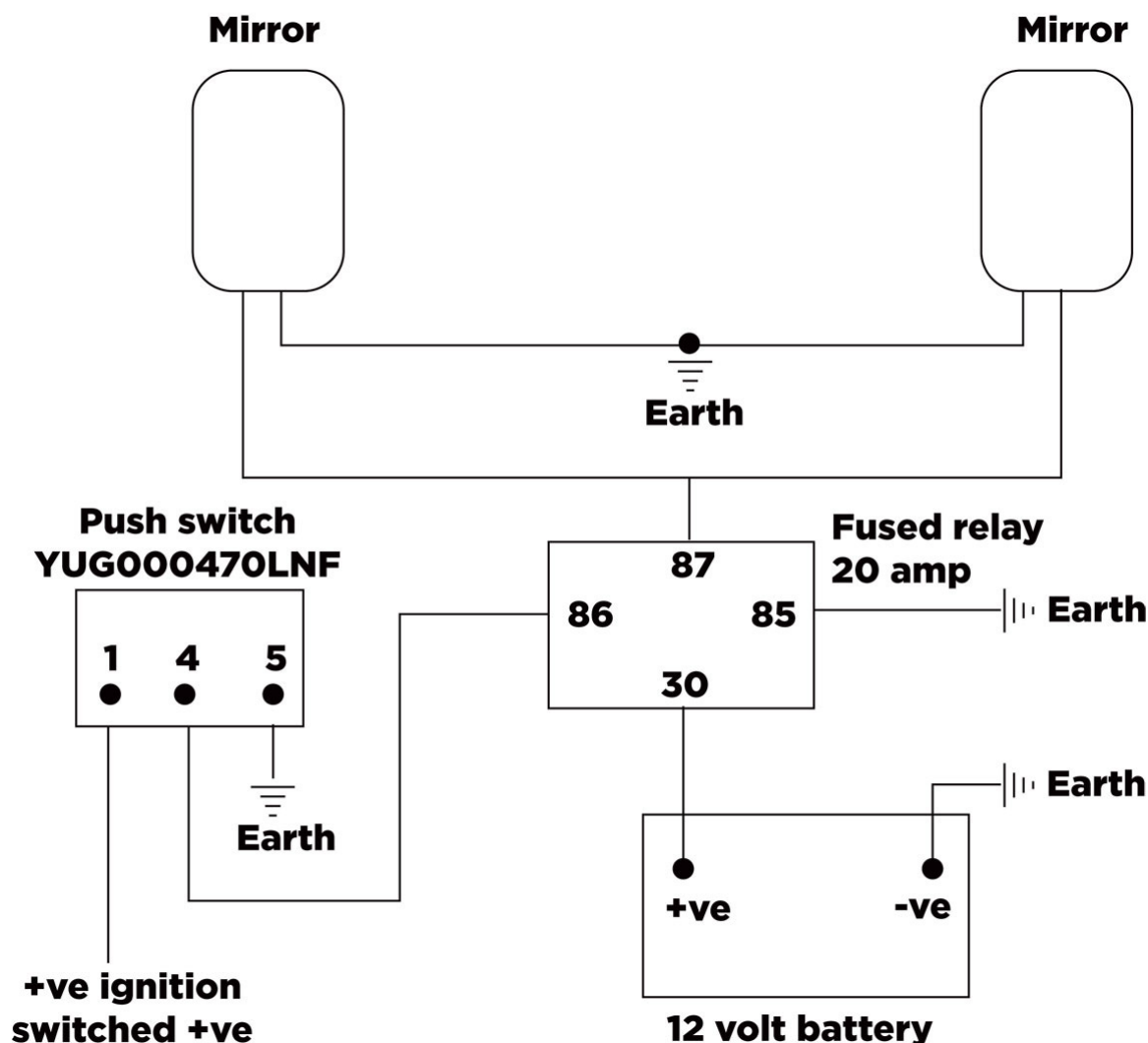

6) Elements can be peeled off the mirror back and re-attached.

7) No liability is accepted for breakage of mirrors or wiring faults. If unsure about the wiring and installation contact a qualified auto-electrician or ring Extreme 4x4 Ltd on the number below.

Extreme 4x4 Ltd does not accept any responsibility for parts, which are not fitted correctly.

Always drive your vehicle according to the prevailing conditions and your own driving ability.